

WEDDLE GEN 3 S45D CHEVY BELLHOUSING EXTERNAL REFERENCE DIMENSIONS

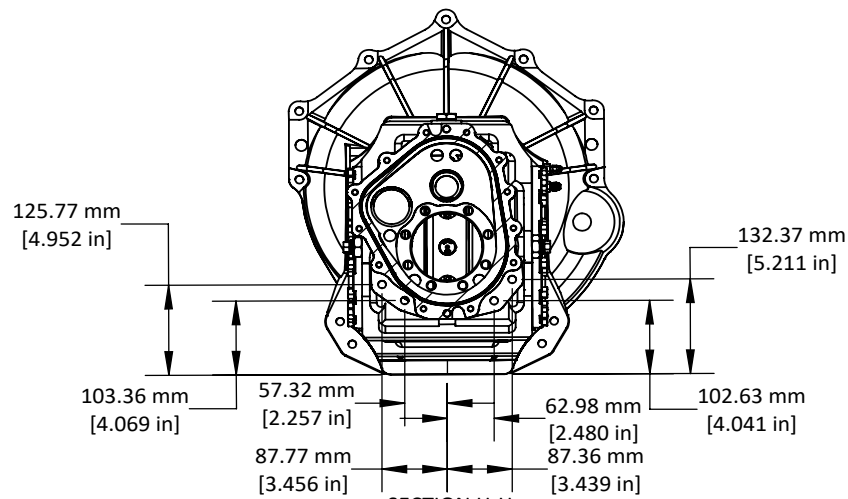

SECTION H-H
Main Case Mounting Hole Detail

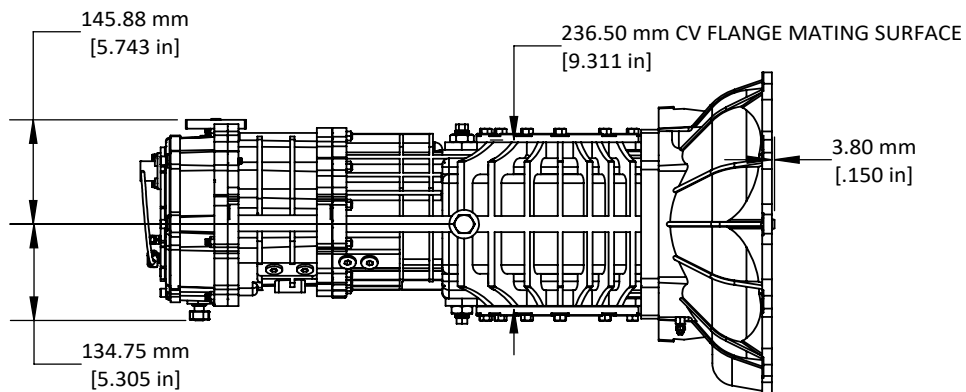
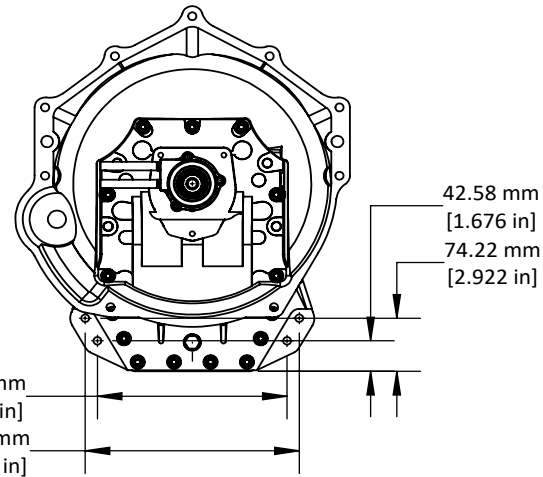
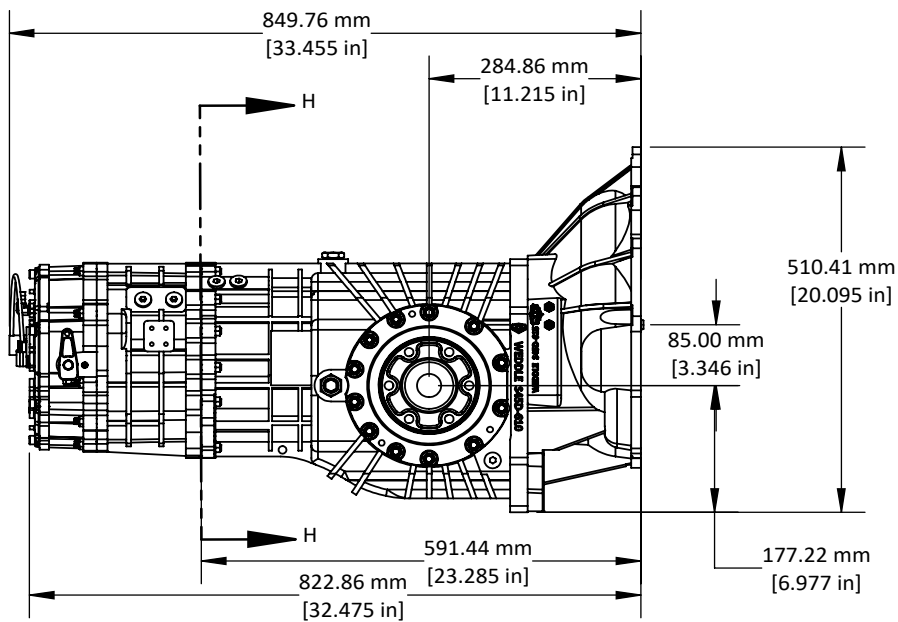

Notes:

1. Dimensions are approximate.
2. Input splines: \varnothing 28.58mm, 26 splines, 30° P.A. (1-1/8" Chevy fine spline).
3. Complete transaxle weight is approximately 93 kg (205lb.)



7200 Hollister Ave, Suite C
Goleta, CA 93117
Ph 805-562-8600 • Fax 805-562-8661
info@weddleindustries.com

Drawing No: WS-DIM-S45D-CH
Drawing Name: S45D External Reference Dims
Drawn By: DL
Revised: 3/21/2022