

WEDDLE GEN 3 S45 VOLKSWAGEN BELLHOUSING EXTERNAL REFERENCE DIMENSIONS

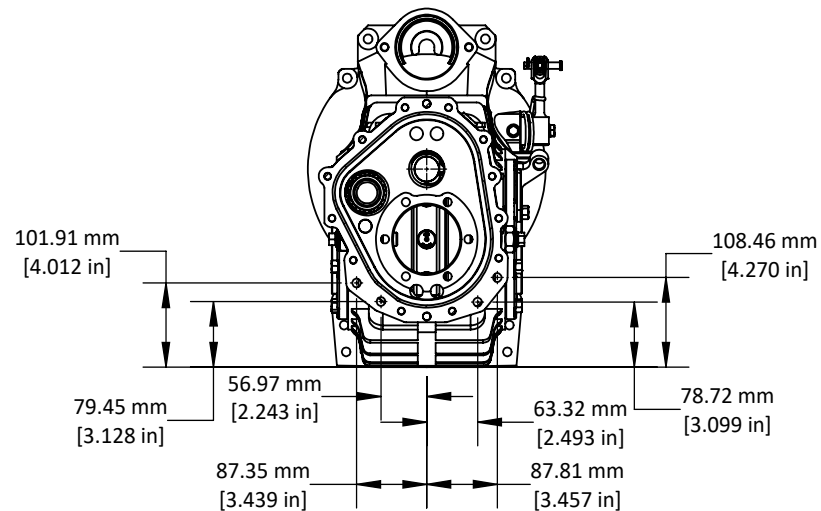

SECTION G-G
Main Case Mounting Hole Detail

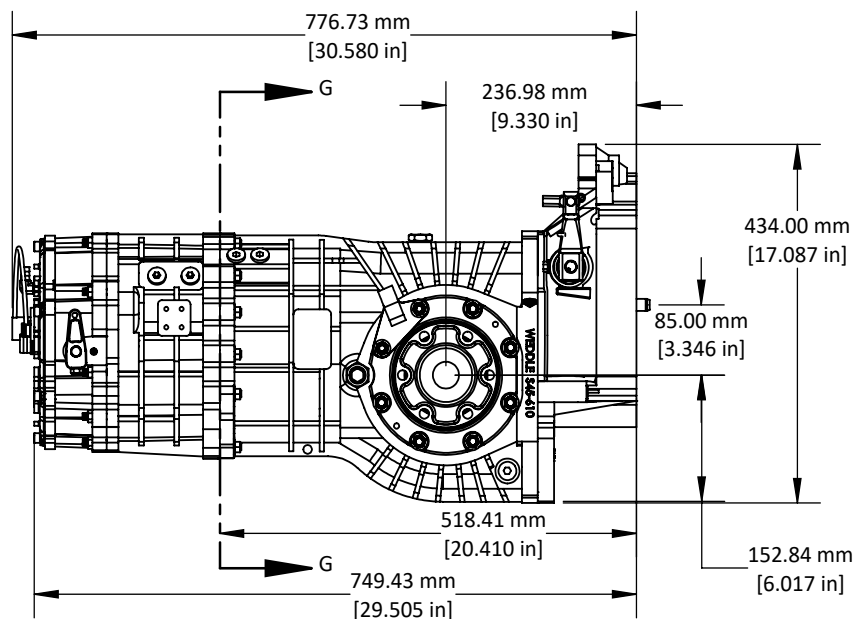
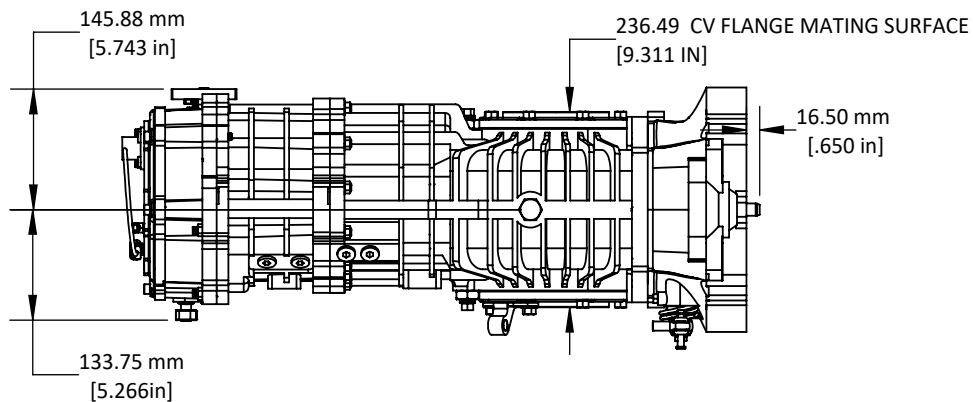
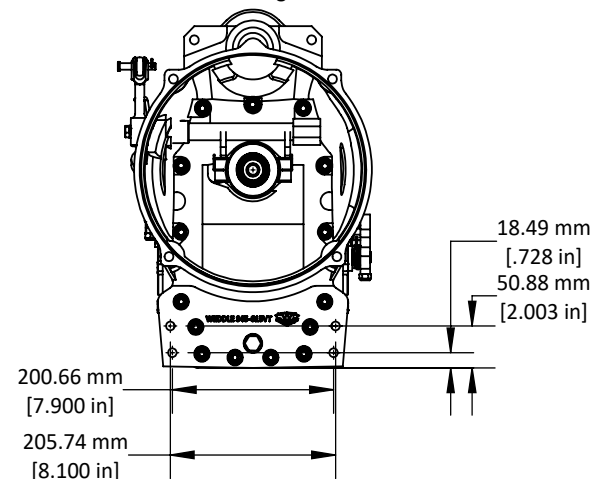

Notes:

1. Dimensions are approximate.
2. 18T Spline (Chrysler Hemi Spline) 16/32 DP, 30°PA
3. Complete transaxle weight is approximately 84 kg (185lb).



7200 Hollister Ave, Suite C
Goleta, CA 93117
Ph 805-562-8600 • Fax 805-562-8661
info@weddleindustries.com

Drawing No: WS-DIM-S45-VW
Drawing Name: S45 External Reference Dims
Drawn By: DL
Revised: 3/18/2022