

# WEDDLE HV1 EXTERNAL REFERENCE DIMENSIONS

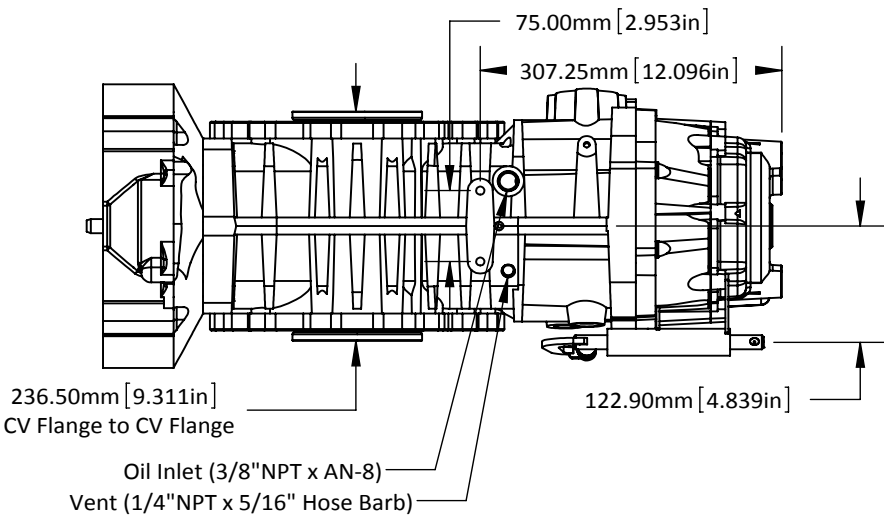

**Notes:**

1. Input splines:  $\varnothing$  28.58mm, 26 splines, 30° P.A. (1-1/8" Chevy fine spline).
2. Clutch release bearing available convex or flat, to suit various clutches.
3. Complete transaxle weighs 61 kg (134lb.) with steel diff.
4. Dimensions are approximate.

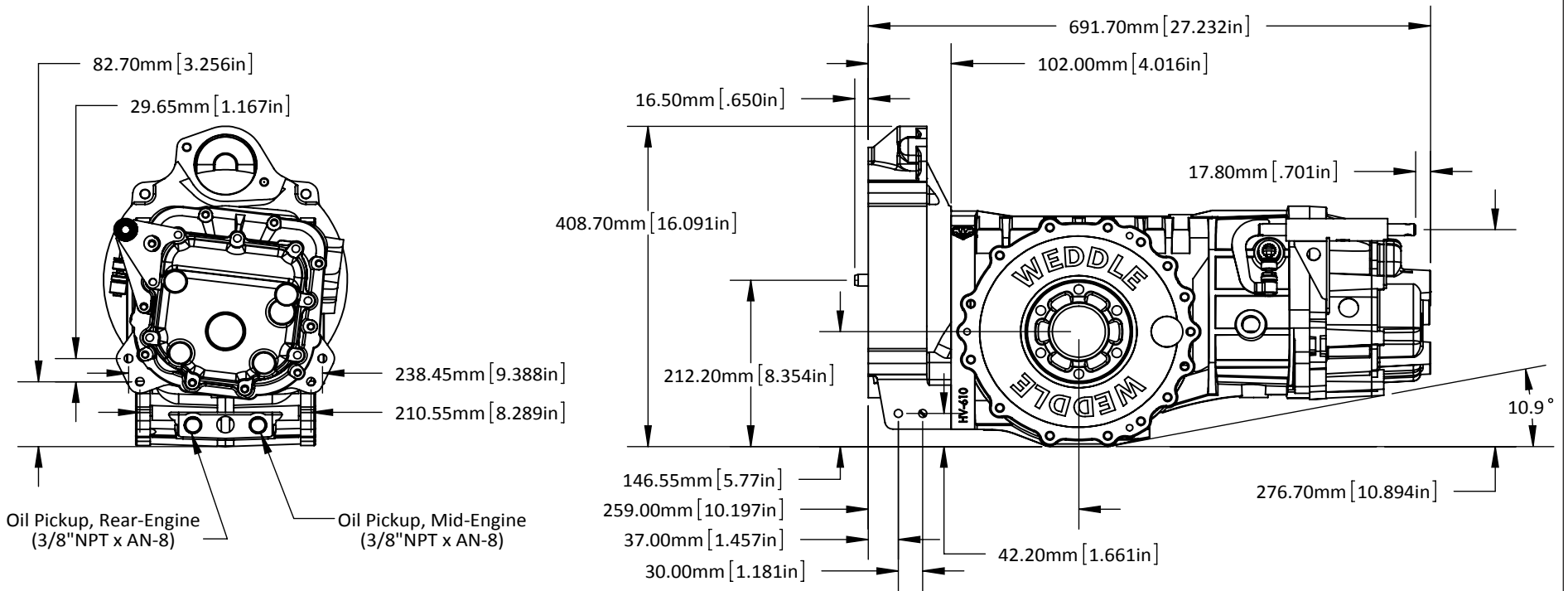

7200 Hollister Ave, Suite C  
 Goleta, CA 93117  
 Ph 805-562-8600 • Fax 805-562-8661  
 info@weddleindustries.com

Drawing No: HV-DIM-HV1  
 Drawing Name: HV1 External Reference Dims  
 Drawn By: DY  
 Revised: 04/09/20