

AGB 10" 5 SPEED SEQUENTIAL CHEVY BELLHOUSING EXTERNAL REFERENCE DIMENSIONS

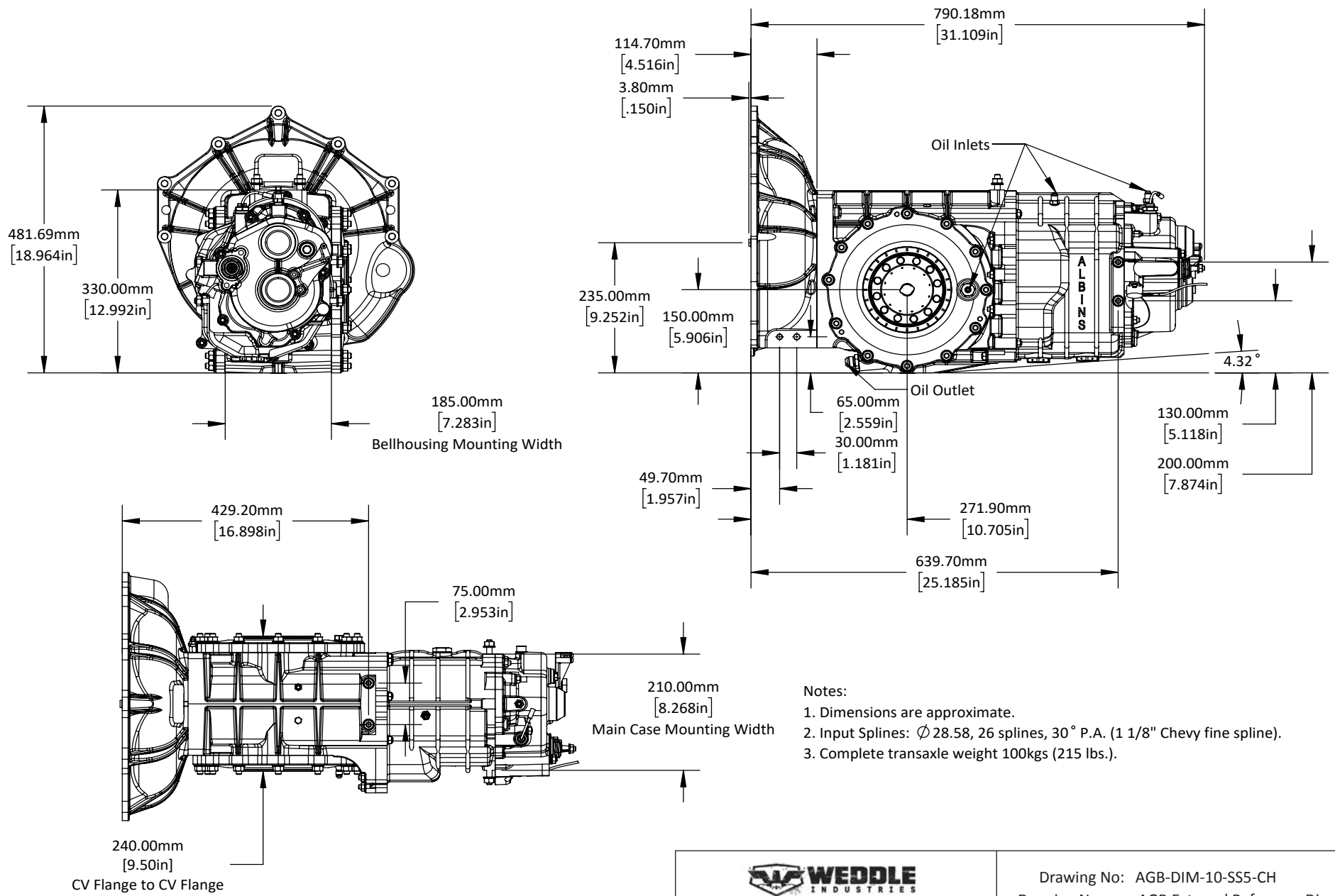

Notes:

1. Dimensions are approximate.
2. Input Splines: $\varnothing 28.58$, 26 splines, 30° P.A. (1 1/8" Chevy fine spline).
3. Complete transaxle weight 100kgs (215 lbs.).



7200 Hollister Ave, Suite C
Goleta, CA 93117
Ph 805-562-8600 • Fax 805-562-8661
info@weddleindustries.com

Drawing No: AGB-DIM-10-SS5-CH
Drawing Name: AGB External Reference Dims
Drawn By: DL
Revised: 06/9/2022