

# HV1 TRANSAXLE EXTERNAL DIMENSIONS

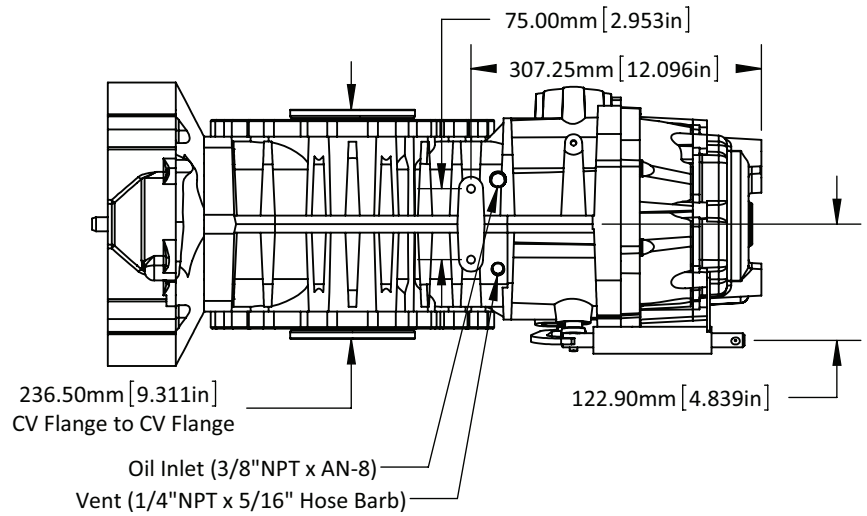
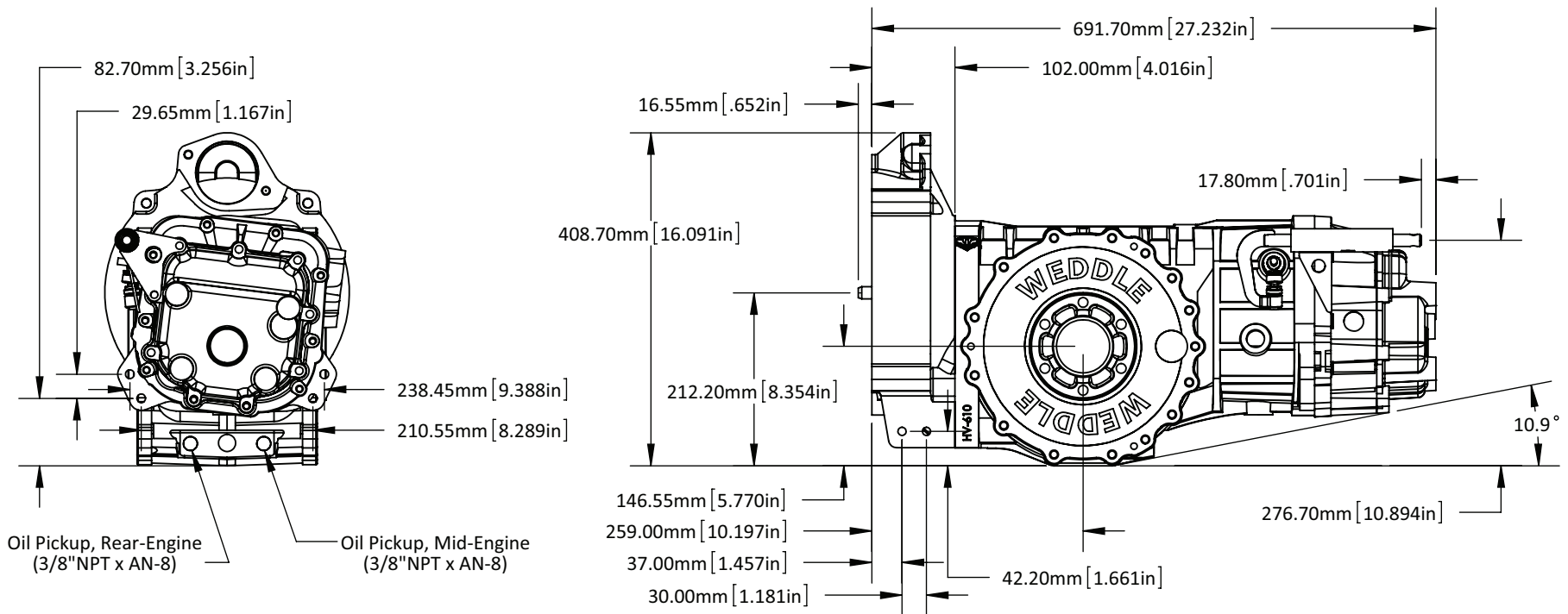

- Notes:
1. Input splines:  $\varnothing 28.58\text{mm}$ , 26 splines, 30° P.A. (1-1/8" Chevy fine spline).
  2. Clutch release bearing available convex or flat, to suit various clutches.
  3. Complete transaxle weighs 61kg (134 lb.) with steel diff.
  4. Dimensions are approximate.

**WEDDLE INDUSTRIES**  
 7200 Hollister Ave, Suite C  
 Goleta, CA 93117  
 Ph 805-562-8600 • Fax 805-562-8661  
 info@weddleindustries.com

Drawing No: HV1-EXTDIM  
 Drawing Name: HV1 External Dimensions  
 Drawn By: D.S. November 12, 2010  
 Revised: D.S. February 16, 2011